



2001 MAGNUM SERVICE MANUAL

CONGRATULATIONS FOR CHOOSING THE LATEST STATE OF THE ART MOUNTAIN BIKE SUSPENSION FORK AVAILABLE. 2001 MANITOU MAGNUM FORK MODELS HAVE STATE OF THE ART MCU/SPRING COMPRESSION SYSTEMS. THE MAGNUM R IN THE MAGNUM SERIES USES THE NEW TWIN PISTON CARTRIDGE SYSTEM (TPC SPORT) THAT SURPASS ALL OTHER TYPES OF OIL DAMPED SYSTEM IN PERFORMANCE AND DURABILITY.

Your 2001 MAGNUM Fork is fully assembled and ready to be installed onto your bicycle. It comes equipped with a 1 1/8 threadless steerer tube. 2001 MAGNUM are sold with the V-Brake cable hangerless arch, but have an optional attachable cable hanger kit P/N 85-4100, which is available through your dealer.

CONSUMER SAFETY INFORMATION

GENERAL WARNING: Bicycling is a hazardous activity that requires that the rider stay in control of his or her bicycle at all times. Reading this manual entirely and properly maintaining your bicycle and suspension fork will reduce the possibility of injury or death. Prior to riding your bicycle, you should inspect your suspension fork to ensure that no damage has occurred during the course of riding. Do not ride your bicycle if the fork shows any signs of bending, cracking, leaking, or if it is missing any of the originally supplied components. Any fall from your bicycle can result in serious injury or even death. Following these instructions can help you reduce the risk of being injured.

If you are a moderate or aggressive off-road rider, or ride at least three times a week over rough terrain, Answer recommends returning your suspension fork every 2 years for a thorough inspection and update. Take your fork to a Manitou authorized dealer who can arrange for shipment to Answer Products, or you may call Answer at (661) 257-4411 to have your fork shipped directly.

IMPORTANT: 2001 MAGNUM Forks are off road forks and as such, do not come with the reflectors installed for on road use. Reflector bracket kit P/N 85-3674 is available through your dealer. Have your dealer or mechanic install the kit to meet the Consumer Product Safety Commission's (C.P.S.C.) Requirements for Bicycles if the fork is going to be used on public roads at any time. If you have questions regarding C.P.S.C. Standards contact your dealer.

- 1 Never remove or have the steer tube or stanchions (inner legs) removed from the crown. The steer tube and stanchions are press fit assembled at the factory. Pressing them out will permanently damage the crown, steer tube, and stanchions beyond repair and render them unsafe for any continued use.
- 2 Never attempt to thread a threadless steer tube. Machining threads will weaken the steer tube and cause an unsafe condition. The only safe thing to do is to obtain the proper crown/steerer from your dealer.
- 3 Any other alterations or modifications to your fork should be considered unsafe. Contact Answer Products Technical Support at (661) 257-4411 prior to modifying your fork in any way for safety information.
- 4 Do not use any Manitou fork if any parts appear to be broken, bent, cracked, or damaged. Contact your dealer or Answer Products Technical Support. If you have any questions concerning the integrity, condition, or safe operation of your fork.
- 5 Answer Products recommends that you periodically inspect your fork for wear and damage. Inspect the crown, stanchions, and outer leg dropout, and brake arch areas for cracks or damage. Before every ride, check to ensure that the proper preload exists.

WARRANTY INFORMATION

Any Answer Products fork found by the factory to be defective in materials and/or workmanship within one year from the date of purchase will be repaired or replaced at the option of the manufacturer, free of charge, when received at the factory, freight prepaid. This warranty does not cover breakage, bending, or damage that may result from crashes or falls. This warranty does not cover any fork that has been modified, subject to misuse, or whose serial number has been altered, defaced or removed. This warranty does not cover paint damage. Any modifications made by the user will render the warranty null and void. This warranty is expressly in lieu of all other warranties, and any implied are limited in duration to the same duration as the expressed warranty herein. Answer Products shall not be liable for any incidental or consequential damages.

If for any reason warranty work is necessary, return the fork to the place of purchase. In the USA, dealers should call Answer Products for a return authorization number (RA#). At that time, instructions for repair, return, or replacement shall be given. Customers in countries other than USA should contact their dealer or local distributor.

INSTALLATION INSTRUCTIONS

Ensure that the proper steer tube has been delivered on your fork. The steer tube may need to be cut to length to fit your bicycle head tube. If you are not familiar with this procedure, or do not have the proper tools to cut the steer tube, it is recommended that you seek a dealer with a qualified bicycle mechanic to perform installation.

WARNING: The steer tube and stanchions (inner legs) are a one time precision press fit at the factory and cannot be removed from the crown. Replacement of the entire crown/steerer assembly must be done to change steer tube lengths or diameters. Removing and replacing the steer tube or stanchions will result in an unsafe condition and should never be done.

- 1 Remove old fork from bicycle.
- 2 Measure and cut the steer tube to the same length as the old fork.
- 3 Remove crown race from old fork and press onto steerer until seated on crown. Figure 1
- 4 Clean and grease headset bearings and races of bicycle.
- 5 Install lower bearings on fork crown race.
- 6 Insert steer tube into head tube of frame.
- 7 Install upper bearings, spacers, and stem.
- 8 Install stem cap, adjust, and tighten headset per manufacture's instructions.
- 9 Torque stem handlebar pinch screw and stem clamping system to manufacturer's instructions.
- 10 Install cantilever brakes and adjust per manufacturer's instructions.

Note: All 2001 MAGNUM forks are equipped with a secondary catch dropout.

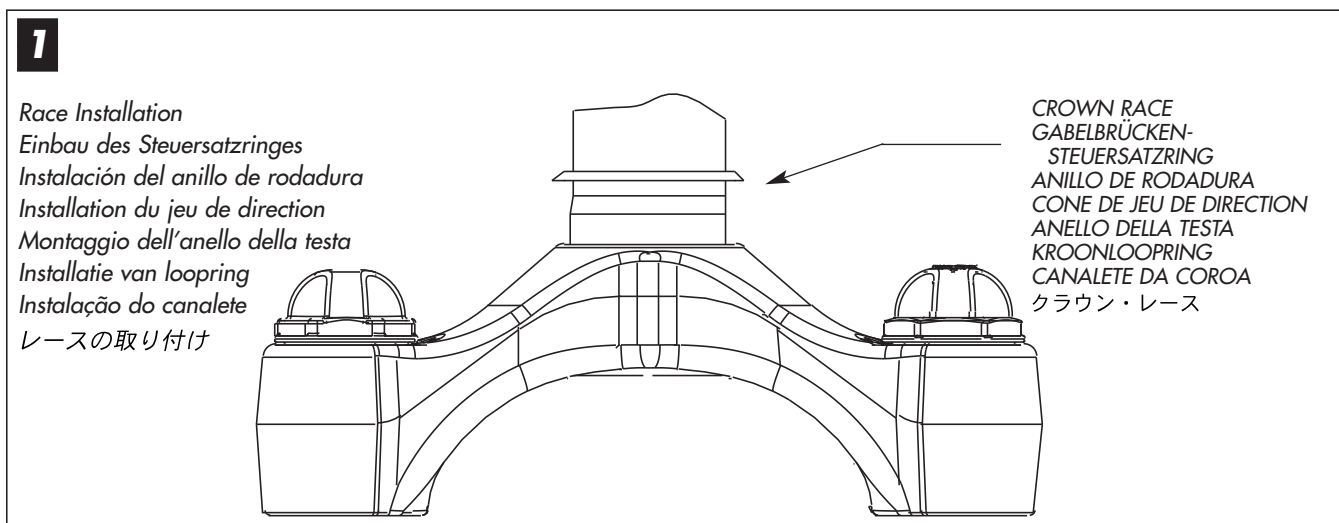

2

Tire clearance
 Reifenabstand
 Espacio libre de la cubierta
 Distance arceau/pneu
 Spazio libero del pneumatico
 Bandspeling
 Folga do pneu
 タイヤクリアランス

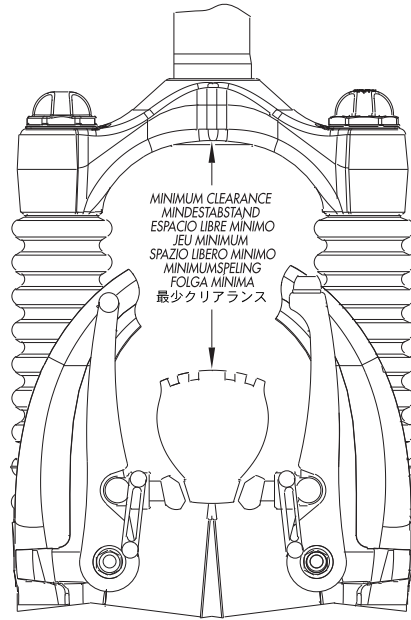

FORK MODEL GABELMODELL MODELO DE HORQUILLA MODELE DE FOURCHE MODELLO DI FORCELLA VORKMODEL MODELO DO GARFO フォーク・モデル	MINIMUM CLEARANCE MINDESTABSTAND ESPACIO LIBRE MINIMO JEU MINIMUM SPAZIO LIBERO MINIMO MINIMUMSPELING FOLGA MINIMA 最少クリアランス
MAGNUM & MAGNUM R 76 mm travel forks	3.1" (78.7 mm)
MAGNUM und MAGNUM R Gabel mit 76 mm Auslenkung	78,7 mm
Horquillas MAGNUM y MAGNUM R con recorrido de 76 mm	78,7 mm
Fourches MAGNUM et MAGNUM R ayant une course de 76 mm	78,7 mm
Forcelle MAGNUM e MAGNUM R con corsa da 76 mm	78,7 mm
MAGNUM & MAGNUM R loop van 76 mm	78,7 mm
MAGNUM e MAGNUM R curso de 76 mm	78,7 mm
マグナムとマグナム R 76 mm 動程	78.7 mm

- 11 Adjust front wheel quick release to clear the 0.275 (7mm) thick secondary catch dropout. The quick release must be tightened after it is properly seated into the dropout counter bores. Ensure that there is adequate thread engagement (4 or more threads with the release adjusted to lock) due to the wide adjustment. Install front wheel to bicycle per manufacturer's specification.
- 12 Install brake cable per manufacturer's instructions.

Note: 2001 MAGNUM forks come equipped with a hangerless arch. Brake cable hangers that attach to the arch are available through your dealer.

WARNING: When installing the wheel or any new tire, check the minimum tire clearance. Measure from the highest point on the tire to the bottom of the crown. The minimum clearance allowed for 76MM travel forks models are 3.1(78.7MM). Any less clearance can result in an accident with the possibility of serious injury or death.

BUSHING & SEAL DETAIL

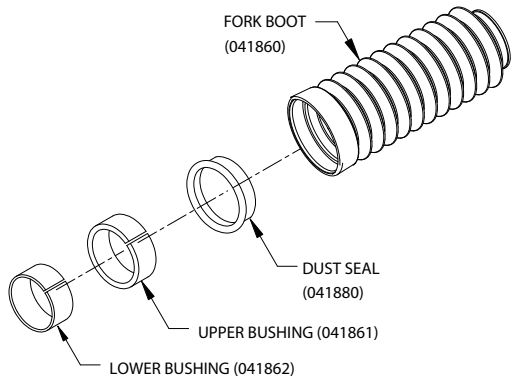

2001 MAGNUM FORK SCHEMATIC

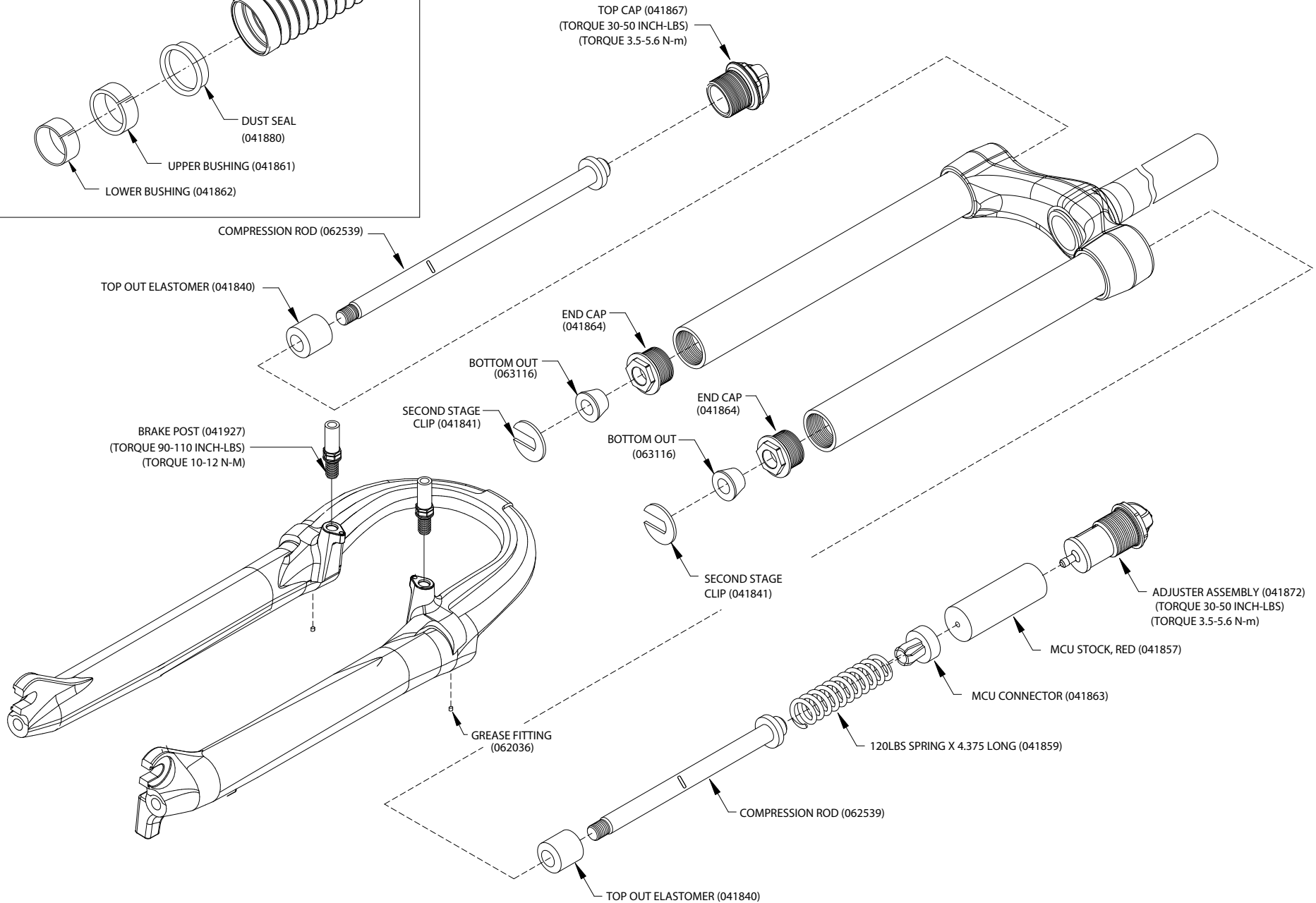

BUSHING & SEAL DETAIL

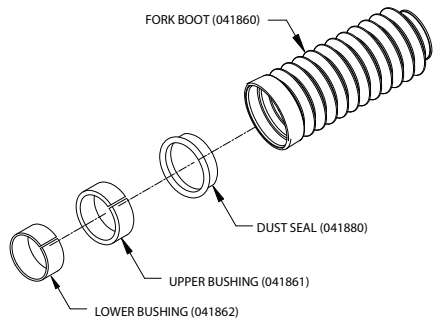

2001 MAGNUM R FORK SCHEMATIC

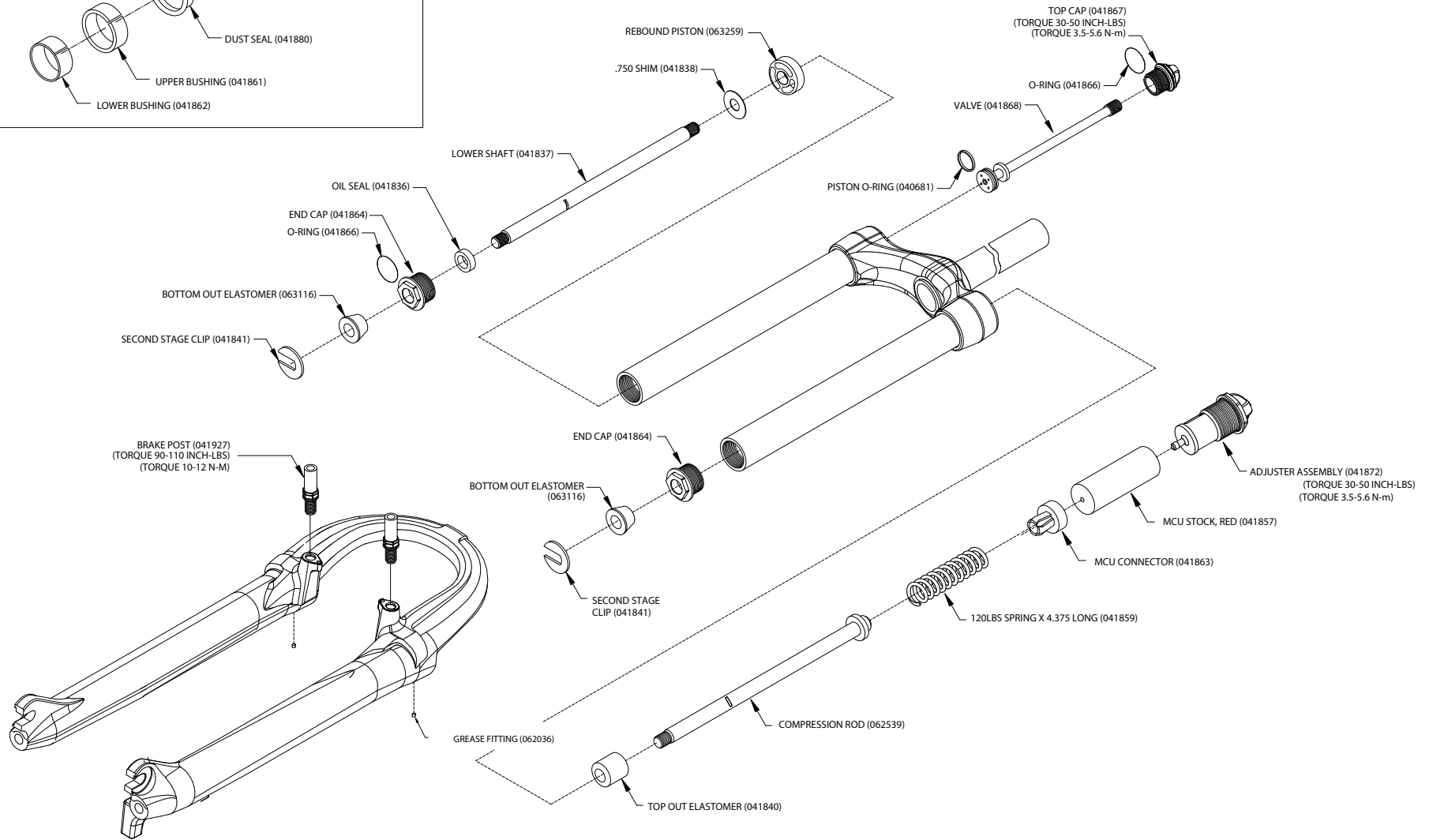

table 1 (cont.)

DESCRIPTION	PART NUMBER
2001 SX & SX R SOFT RIDE KIT	85-9127
2001 SX & SX R FIRM RIDE KIT	85-9129
2001 SX 100 SOFT RIDE KIT	85-9184
2001 SX 100 FIRM RIDE KIT	85-9186
2001 BLACK SX OUTER ASSEMBLY WITHOUT STICKERS	85-9191
2001 YELLOW SX OUTER ASSEMBLY WITHOUT STICKERS	85-9194
2001 RED SX OUTER ASSEMBLY WITHOUT STICKERS	85-9196
2001 BLUE SX OUTER ASSEMBLY WITHOUT STICKERS	85-9197
2001 FIREBALL SX OUTER ASSEMBLY WITHOUT STICKERS	85-9198
2001 COBALT SX OUTER ASSEMBLY WITHOUT STICKERS	85-9199
2001 WHITE SX OUTER ASSEMBLY WITHOUT STICKERS	85-9202
2001 SX & SX E STEER/LEG ASSEMBLY	85-920
2001 SX R & SX 100 STEER LEG ASSEMBLY	85-9208
2001 SX R ALLOY STEER/LEG ASSEMBLY	85-9209
2001 SX E X-FIRM RIDE KIT	85-9218
2001 SX & SX R X-FIRM RIDE KIT	85-9219
2001 SX 100 X-FIRM RIDE KIT	85-9223
2001 SX REBOUND DAMPING ASSEMBLY KIT	85-9266
2001 SX 100 REBOUND DAMPING ASSEMBLY KIT	85-9267
2001 SX R REBOUND DAMPING ASSEMBLY KIT	85-9268
2001 SX & SX 100 COMPRESSION DAMPING ASSEMBLY	85-9269

MAINTENANCE

IMPORTANT: 2001 SX forks should not be used if any parts appear to be or are damaged. Contact your local dealer or Answer Products for replacement parts.

IMPORTANT: Use of fork boots is required to keep your 2001 SX performing well and your warranty in effect. Use of this fork without boots will shorten the life of the fork, reduce the performance and void the warranty.

Your 2001 SX Fork requires periodic maintenance, cleaning, and inspection. Moisture and contamination may build up inside the fork depending on the severity of riding conditions. To maintain top performance it is recommended that the fork be periodically disassembled, cleaned, dried and re-greased.

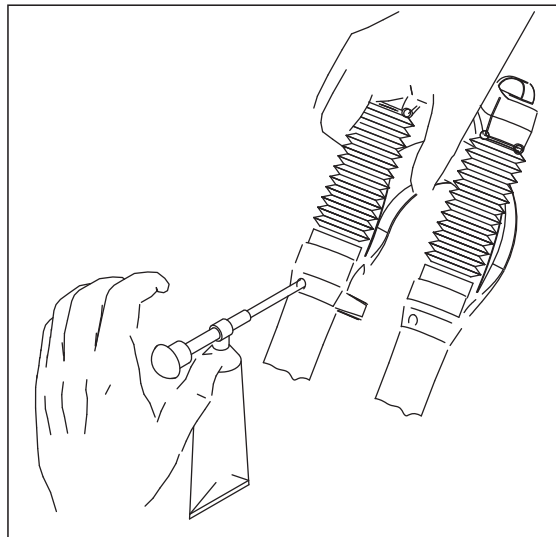

IMPORTANT: When filling the fork with grease through the Microlube grease ports it is important to note the grease is being forced between the upper and lower bushing (Figure 7). If the area is over-filled, the force of the grease may force the upper bushing and dust seal out.

IMPORTANT: Before every ride you should:

- 1 Ensure that quick release skewers are properly adjusted and tight.
- 2 Wipe the inner legs clean, lubricate and check entire fork for any obvious damage.
- 3 Check headset adjustment.
- 4 Ensure that the front brake cable is properly seated in the cable retainer & check brake adjustment.

IMPORTANT: Maintaining the proper oil level in your TPC is very important. Not enough oil will allow foaming and reduce the performance. Too much oil will restrict travel and may cause damage to the system and an unsafe riding situation. Finish reading this entire section prior to making any changes to the oil level.

CHECKING OIL LEVEL FIGURE 8:

To check the oil level, remove only the compression damping assembly located in the top of the right leg. Leave the left side compression stack (adjuster, MCU, spring assembly) in place to keep the fork fully extended. Use a tape measure or dip stick to determine the oil level. Oil level should be between 3.75 (95.2mm) and 4.75 (120.6mm) below the crown where the damping assembly screws in (see figure 8). The recommended level is 4.25" (107.9mm). It is recommended that you replace your oil at least once a year, twice if it has been contaminated with dirt, mud, or other foreign substance. Use SAE 5WT Maxima fork oil or equivalent.

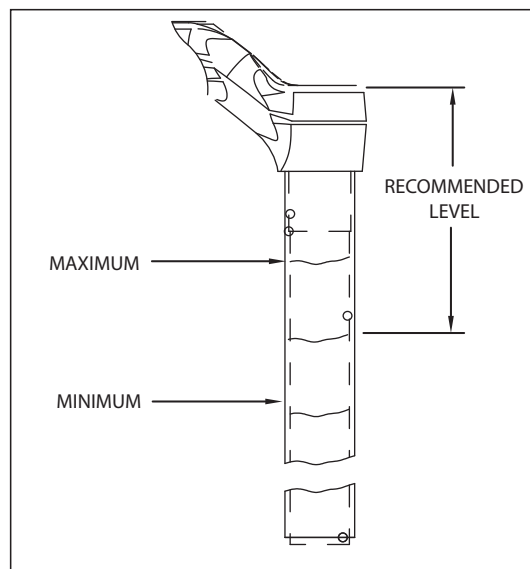

Removal of outer leg / arch assembly:

- 1 Use a 4MM allen wrench to remove the M5 lower compression rod screw from the left leg dropout. Pop out the damping adjuster knob from the right dropout, SXR. A small screwdriver may be helpful. Use an 8MM Allen wrench to remove the dropout nut. Fully compress the fork to prevent the compression rod and damper shaft from turning while removing screws.
- 2 Pull outer leg assembly down to remove from the inner legs and crown.
- 3 Remove fork boots.
- 4 Bushing replacement will require the use of the bushing removal and installation tool available from Answer Products. It is recommended that the bushings be left installed unless they absolutely need replacement.

Note: It is not recommended to remove the dust seal every time the fork is disassembled. The seal and bushings may be cleaned and re-greased in place.

GENERAL DISASSEMBLY

NOTE: The Fork does not need to be removed from the bicycle for general disassembly-assembly or cleaning. It is also not necessary to disassemble the 2001 Manitou Forks for compression elastomer replacement. Elastomer replacement is accomplished by removing the adjuster assembly per Figure 10.

Compression Stack & Compression Rod

- 1 Press the bottom clip off the compression rod.
- 2 Slide off the rebound elastomer from left leg compression rod.
- 3 Unscrew and remove the adjuster assembly by hand.
- 4 Turn fork upside down to remove the compression rod. If forks are installed on bicycle give the rod a quick upward thrust and catch it as it pops up above the crown.

Lower Shaft Disassembly:

Note: Lower Shaft disassembly is best done with the fork removed from the bicycle. Disassembly of the damping stack is not required unless you want to change or replace the shim stack.

- 1 Remove the left cap compression damping assembly from the top of the fork leg and pour the oil out of the top of the fork and discard appropriately. For complete disassembly continue.
- 2 Remove the plastic end cap and pull the lower shaft out of the inner leg.
- 3 Remove the clear plastic detent sleeve and capture the 1/8 dia. Detent ball used on SX R only.
- 4 SX R adjuster needle may be unscrewed from the shaft.
- 5 For SX R use 5MM allen wrench to remove piston seat. Keep note of the exact order of the shims and spacers.

Compression Damping Disassembly:

- 1 The compression damping assembly is almost identical to the lower shaft assembly.
- 2 Unscrew the compression damping adjuster all the way until it stops. The knob and the needle do not need to be removed. The shaft also does not need to be removed from the cap. The threads are bonded to prevent leaking.
- 3 Remove either the valve nut or the piston seat following the instructions above for the lower shaft assembly.

DAMPER INSPECTION

- 1 Check the shaft for scratches, wear, or other obvious damage.
- 2 Check the seal gland and end cap seal grooves for damage.
- 4 Check shims for permanent bends or damage.
- 5 Check all other parts for obvious damage, replace if necessary.
- 6 Replace all seals that have been removed.

FORK INSPECTION

- 1 Check the fork boots for obvious damage.
- 2 Check the dust seal for tears, wear, or damage. Replace if needed.
- 3 Inspect the lower and upper bushing for damage to the Teflon coating. Replace using the bushing removal and replacement kits if necessary.
- 4 Check all MCU & springs for obvious damage. Replace if necessary.
- 5 Check the preload adjuster and connectors. Replace if damaged.
- 6 Check the outer leg/arch assembly for nicks or deep gouges on outside and inside. Replace if damaged.
- 7 Check the inner leg for deep gouges and other damage. Minor wear resulting in color change is not detrimental to the gold anodized surface. Replace if wear is excessive or damaged.
- 8 Check inner legs at the bottom of the crown for cracks or for flaking anodize. Replace crown steer leg assembly if cracked or if gold anodize is beginning to flake.
- 9 Check the underside of the crown for cracks. Replace if cracked.

RE-ASSEMBLE

Lower Shaft

- 1 Install all o-rings and seals removed.
- 2 Grease all seals lightly with seal grease.
- 3 Apply small amount of blue Loctite to piston seat threads.
- 4 Assemble shim stack and spacers in exact order that they were removed. For SX R hand tighten piston seat. Be sure large blow off washer will slide over piston spacer and compress the small spring. Clamp shaft in soft jaws or collet and line up slots in clamp ring with hole in piston seat using 1/8" or smaller pin. Use a 5MM Allen wrench and tighten piston seat by turning Allen wrench and pin at same time. Torque 10 IN-LB (3.5 N-m) max.
- 5 SX R install lower needle gently into shaft, thread until it stops then back off one turn for initial adjustment.
- 6 Slide shaft assembly through the plastic end cap, place detent ball in place and slide on 2nd STG Elastomer.
- 7 Insert into left leg and thread in end cap. Torque 30 IN-LB (3.5N-m) max.
- 8 Add approximately 90 CC of 5 WT Maxima or equivalent oil. Do not over fill. Check oil level, see Figure 8.

Compression Damping Assembly

- 1 Reassemble compression damping stack following the instructions above for the lower shaft assembly.
- 2 Install compression damping assembly into the left leg. The oil level should cover the compression valve when the assembly is installed.

Compression Rod & Boots:

- 1 Clean all parts thoroughly.
- 2 Grease compression rod lightly. Be sure rebound Elastomer is installed onto compression rod.
- 3 Drop compression rod down into inner legs. Shake inner leg to get rod through inner leg plug.
- 4 Slide on black second stage, cup washer, and orange 3rd stage Elastomer.
- 5 Slide Boots onto inner leg.

Outer Leg Assembly:

- 1 Slide Outer leg / Arch assembly onto inner legs and fully compress.
- 2 Install and torque 5MM compression rod screw and dropout nut to 10-30 inch-lb. (1.1-3.5 N-m). Over torquing the dropout nut may damage the damper shaft.
- 3 Pop in damper adjuster knob. O-ring holds knob in place (SXR).
- 4 Slide skirt of fork boots onto the outer leg groove. Be sure the lip snaps into the groove.
- 5 Clean adjuster cap threads thoroughly. Clean threads on inside of inner leg.
- 6 Assemble MCU's, springs, and connectors with thick grease.
- 7 Install adjuster assembly into inner leg just hand tight.

INNER FORK LEGS & CROWN

The inner fork legs and steer tube are press fit into the crown and may never be removed. Removing them will make the fork unsafe to use. If you see any slippage contact Answer Technical Staff immediately (800) 670-7446.

ADJUSTING RIDE QUALITIES

2001 SX TPC forks offer a wide adjustment range to suit individual riding preference and rider weight by simply changing the MicroCellular Urethane (MCU's). Fine tune adjustments can be made using the preload adjusters located on top of the fork crown. Softer blue and harder yellow MCU's are available from your Dealer.

NOTE: Since 2001 model forks use a compression stack in the left leg only, MCU's and Springs used in previous Manitou forks are NOT interchangeable with later versions of SX model Forks.

Compression Spring Fine Tuning:

Fine tuning adjustments to the spring rate are made by rotating the adjuster knobs located on top of the crown. Note the 2001 SX 100, SX, and SX R uses compression spring systems in the left leg only. Only the left knob on top of the crown adjusts preload. Rotating the knob clockwise will firm the ride, adding preload to the compression stack. Rotating the knob counter clockwise will soften the ride. Four full revolutions will take the adjuster from full soft to the extreme firm setting.

Compression Damping Fine Tuning:

To adjust the SX R simply rotate the compression damping knob located on top of the right leg and crown. Rotating the knob clockwise will increase the damping, rotating the knob counter clockwise will reduce the damping. Excessive damping will give you a harsh ride over sharp bumps like rocky sections, but will feel good in large hits like G-outs. Insufficient compression damping will bottom out in the large hit G-outs and bob a little while climbing but feel plush on the sharp hits. A correctly adjusted fork will perform good in all conditions. The SX 100 and SX uses TPC Sport for compression damping and is not adjustable.

Rebound Damping Fine Tuning:

To adjust the SX R simply rotate the rebound damping knob located on bottom of the right leg. Rotating the knob clockwise will increase the damping, rotating the knob counter clockwise will reduce the damping. Excessive rebound damping will give you a harsh ride over repetitive bumps (like braking bumps) because the fork will pack up. Insufficient rebound damping will make the fork over active, top out and slap back when landing from a jump. We suggest that you try adjusting your fork on the very active side, minimum rebound. Then try it over a variety of terrain and tune in more rebound from there. The SX 100 and SX uses TPC Sport for Rebound damping and is not adjustable

Lok-Out System Kit P/N 85-8989

Lok-Outs are available for all SX models. By turning the knob 1/4 turn CCW, exposing the green sticker; the front fork will have regular TPC suspension. By turning the knob 1/4 turn CW, exposing the red sticker; the fork will be locked out. A safety blow off valve will open under extreme conditions to allow some movement. To adjust the compression damping when not using the Lok-Out. Remove the compression damping assembly from the top of the right leg. Adjust the setscrew, located in the valve seat, in to increase the damping and out to reduce the compression damping. Try adjusting one 1/2 turn at a time.

For additional tuning tips we recommend that you obtain a copy of the MRD tuning Manual P/N 85-3485 and check out the MRD Race Tuning kits available at your dealer.

TROUBLE SHOOTING

Fork seems to top out or has a slight clunking feel when front wheel comes off the ground:
Excessive preload or insufficient rebound damping will result in a top out. Select MCU's that better fit your weight and riding style, having the preload adjuster set mid to low range, and increase the rebound damping to eliminate top out.

The fork feels less active and is not getting the travel it used to when it was new:
Chances are that the fork is developing stiction. Cleaning and applying light oil to the stanchions will help.

Outer legs feel loose on inner legs and bushings, a knock or rock can be felt when pushed from side to side:
A very small knock is normal with the new harder bushings. If the knock is excessive or you can feel the fork rocking then the bushings should be removed and replaced. To do this you must have the Answer Products Bushing Removal and Replacement Tool Kit.

A small amount of oil seems to be leaking from top of the left leg at the adjuster cap:
If the 2001 SX is stored upside down for a period of time a small amount of oil may leak through the adjuster cap / knob assembly. The cap area is not subjected to damping pressure. A small leak in that area will not affect the performance of the fork or cause any type of damage. We recommend that you store your Manitou left side up. If this condition causes you some problems please contact your Answer Products dealer or call our warranty tech department for prompt service.

CYCLE COMPUTER INSTALLATION INSTRUCTIONS:

Follow the instructions in your owners manual with the following exceptions:

WARNING: DO NOT DRILL A HOLE IN THE DROPOUT. THIS MAY WEAKEN THE DROPOUT, WILL VOID THE WARRANTY, AND MAY CAUSE AN UNSAFE CONDITION WITH RISK OF INJURY. DO NOT USE THE TEMPLATE PROVIDED IN THE 95 OR 96 SERVICE MANUAL.



28209 AVENUE STANFORD • VALENCIA, CA 91355
(661) 257-4411 • www.answerproducts.com