

TITLE		DRAWING No.	
		QS 3Band Logic 4ch Decoder	
		(page 1/6)	
SHEET	DATE	DESIGN	
	2022/3/19		

undeclared OPamp is 4558DD

Direction detector of a sound source

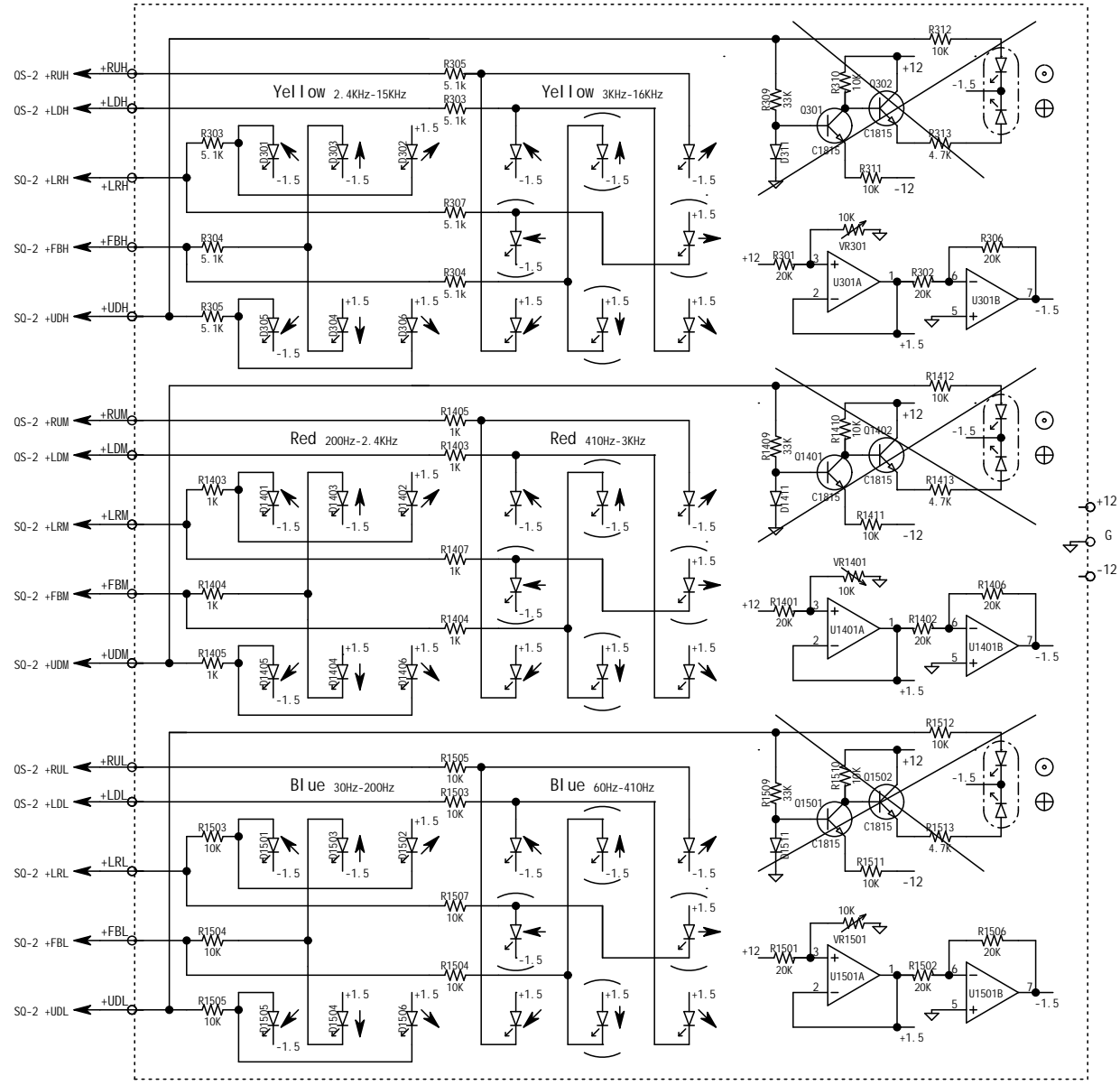

Board QS-1

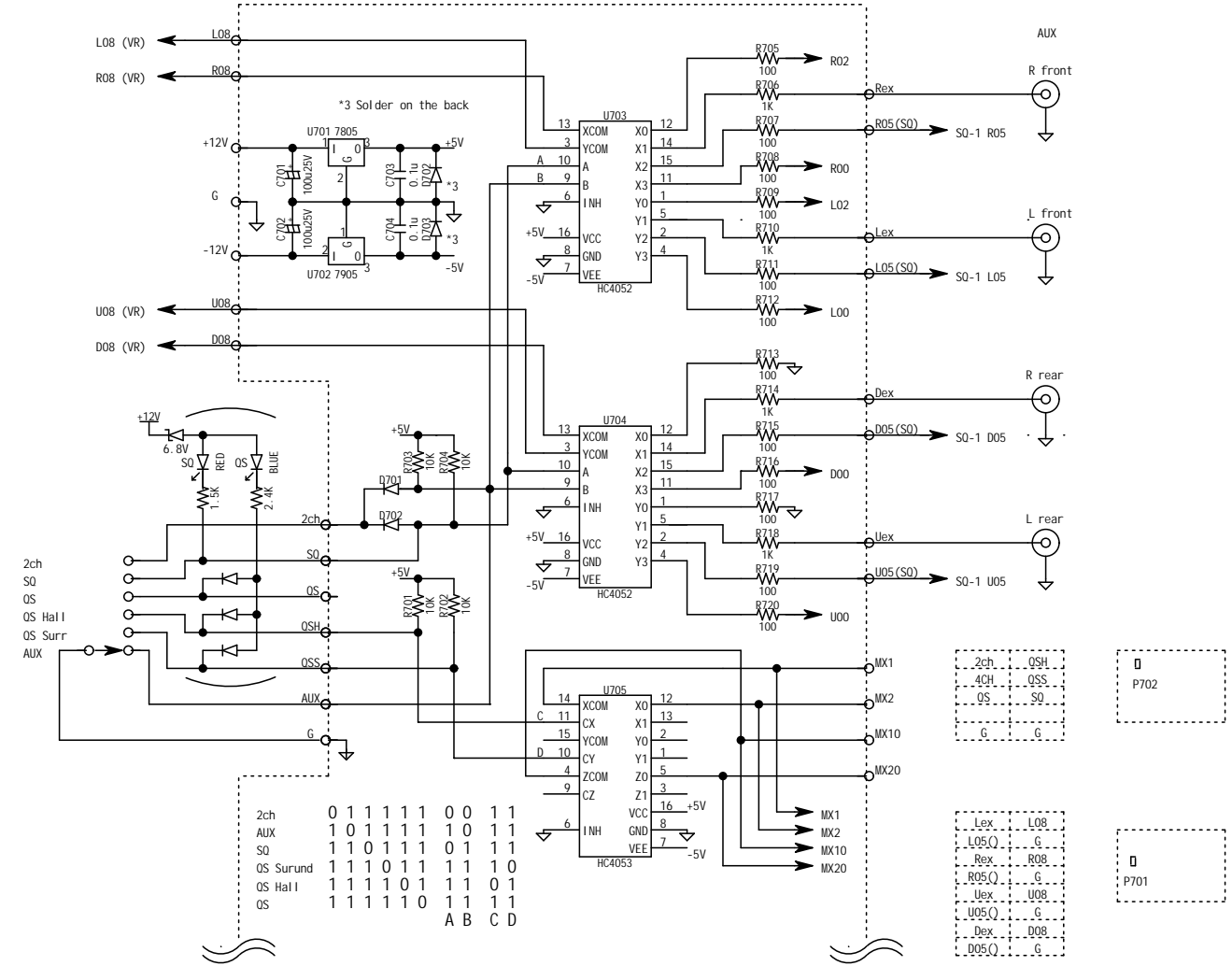

Level Meter

Level Meter

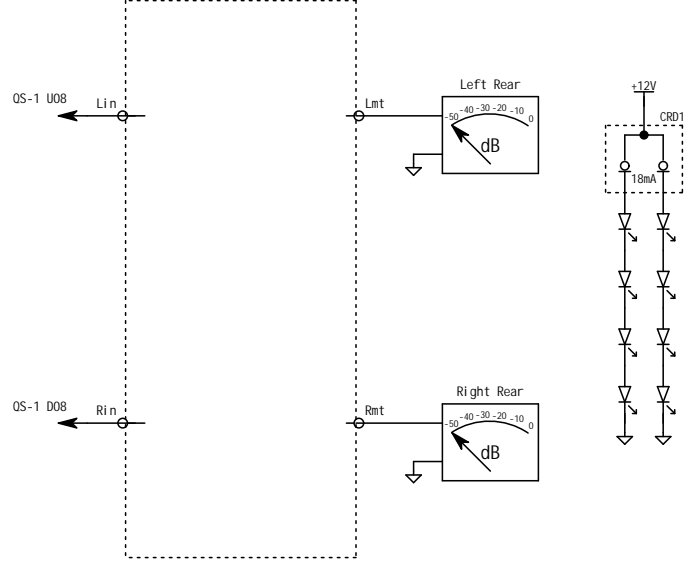
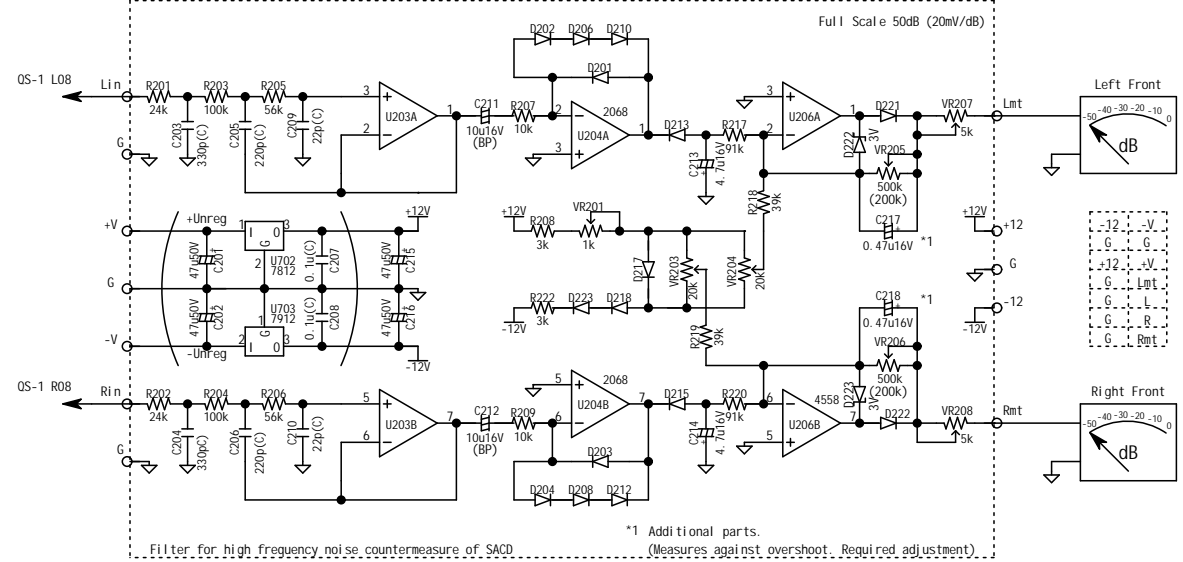

Power Supply

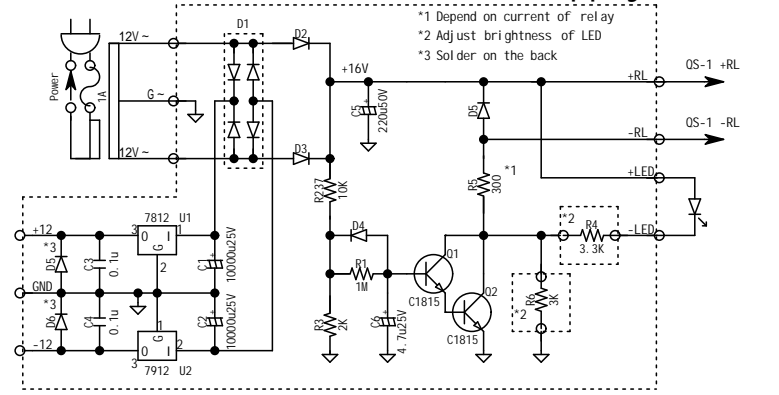

TITLE		DRAWING No.	
		SQ 3Band Logic 4ch Decoder (page 3/6)	
SHEET	DATE	DESIGN	
/	2020/2/25		

undeclared OPamp
is 4558DD

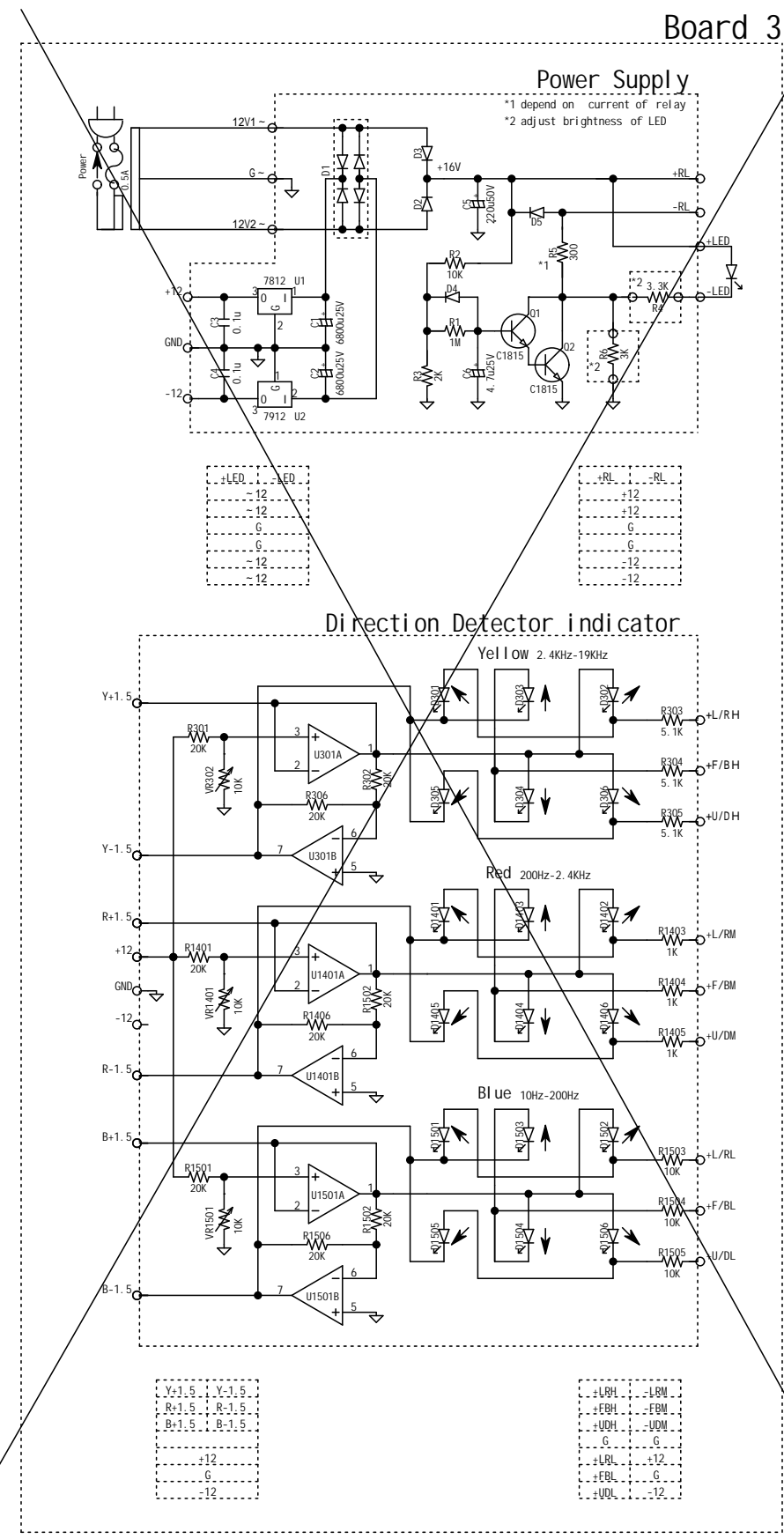
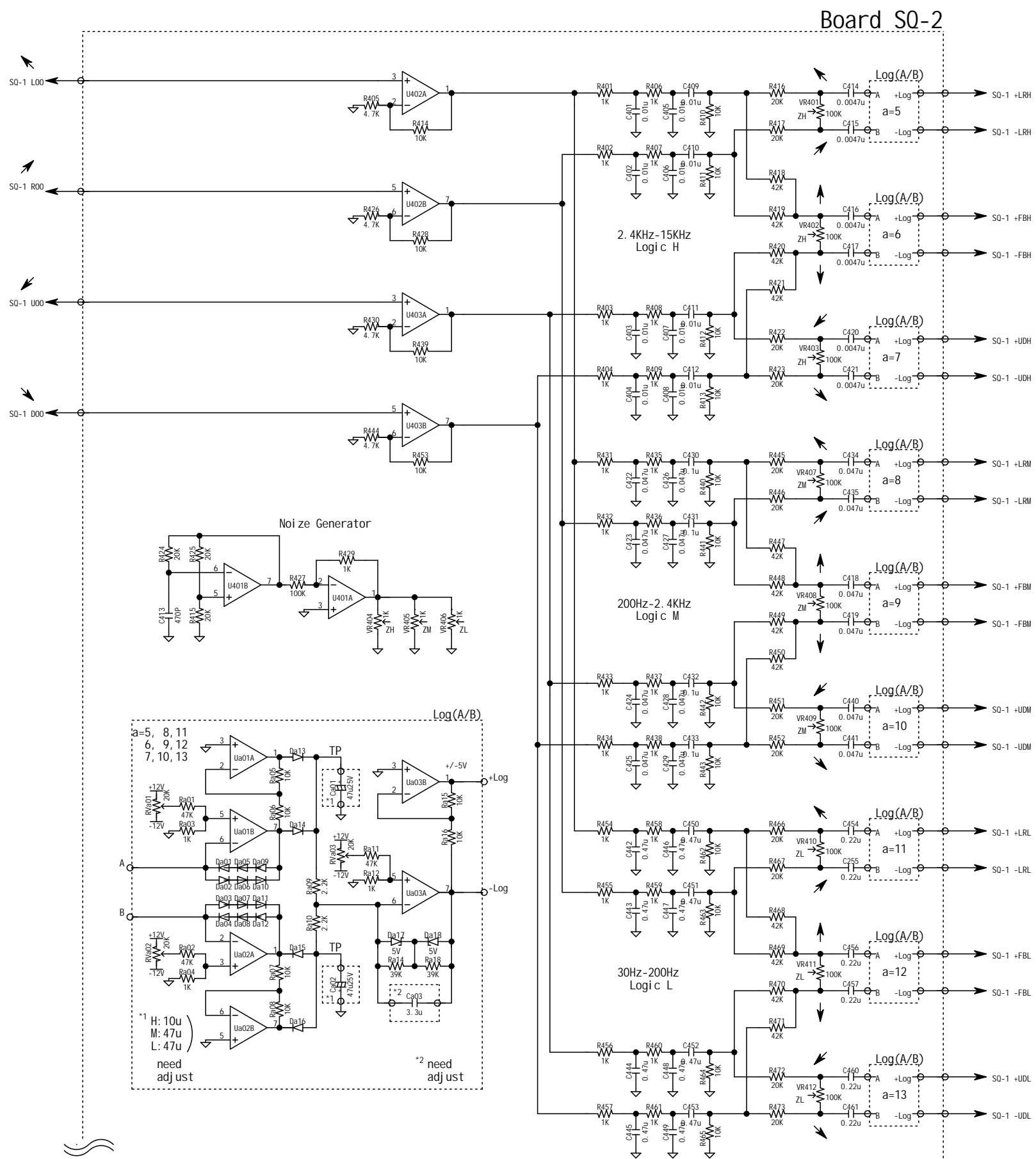

undeclared OPamp
is 4558DD

TITLE		DRAWING No.	
		SQ 3Band Logic 4ch Decoder (page 5/6)	
SHEET	DATE	DESIGN	
/	2020/2/25		

Board SQ-1

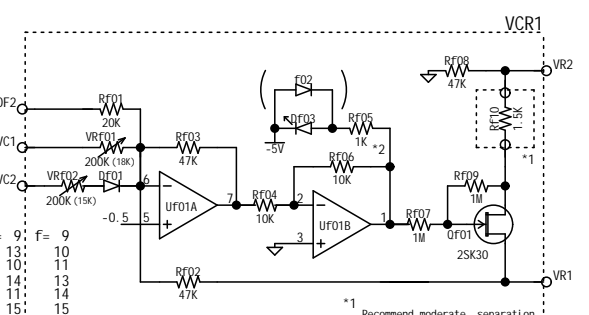
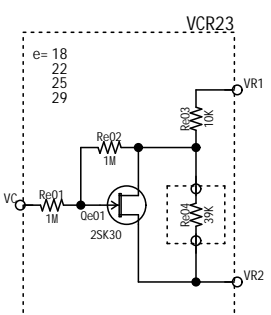
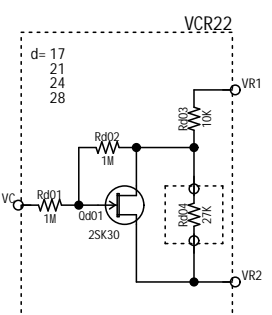
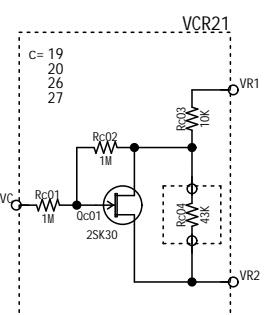
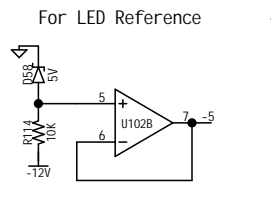
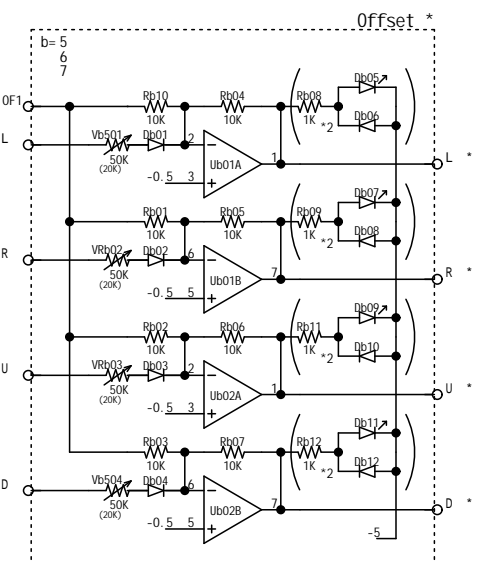
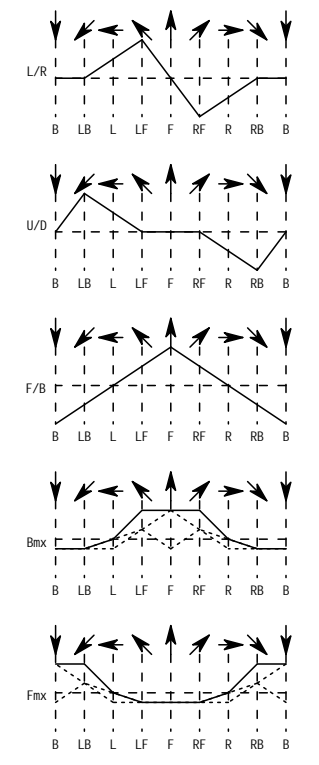
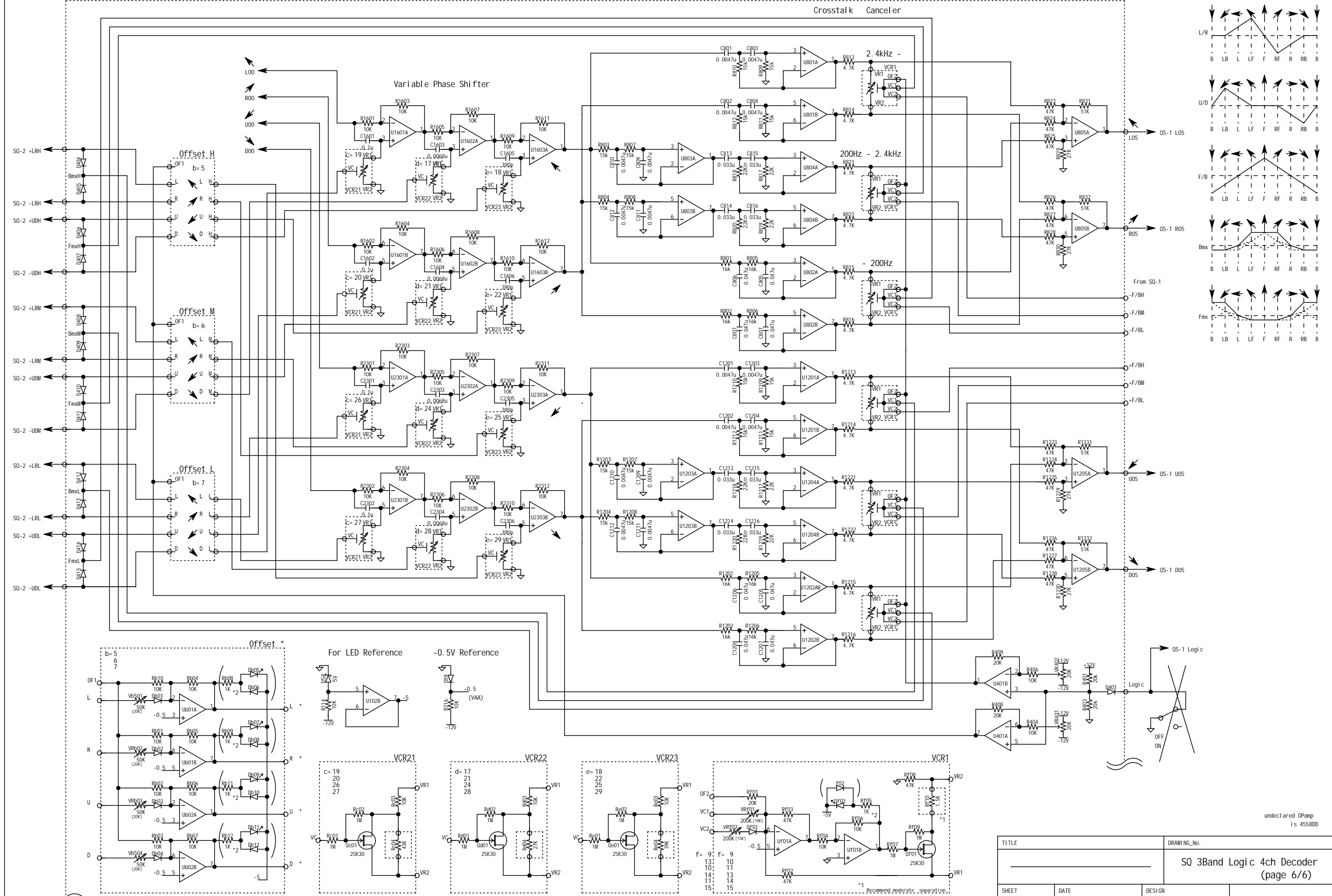

TITLE		DRAWING No.	
		SQ 3Band Logic 4ch Decoder (page 6/6)	
SHEET	DATE	DESIGN	
	2020/2/25		

*2 Necessary adjustment (depends on LED)

undeclared OPamp is 45580D